

Installation manual ValkBox3



Index

Disclaimer	Page 3
Required ballast	Page 4
Safety instructions	Page 5
Required ballast per country	Page 6 - 17
Components	Page 18
Mounting the clevis	Page 19
Mounting the curved supports	Page 19
Mounting panel options	Page 20
Placing the rubber tiles	Page 21
Position the ballast	Page 21
Tighten hinge bolts B1	Page 22
Finish fitting the cables	Page 22
Position the rows one behind each other	Page 22

Pay attention

- This manual is not project specific.
- This manual is not legally binding.
- No rights may be derived from this installation manual.
- See **datasheet ValkCableCare** for cable management.
- The system is placed in the middle zone of the roof.



Disclaimer

This installation manual composed with the greatest possible care and contains specific information for correct and safe installation of the solar mounting system, including installation drawings and ballast tables, calculated according to the Eurocode regulations. The standard values used for input of these calculations, always need to be checked in advance by the installer for correctness. In case values are different, a project case specific calculation needs to be made. Please contact Van der Valk Solar Systems in this situation.

At all times all currently applicable structural, safety and building regulations must be observed prior to installation of the solar mounting system. The building in question will be subject to a load as a result of the solar mounting system installed/mounted. Solar mounting systems installed on roofs will be exposed to wind and snow loads. Therefore, you are at all times responsible to obtain and use a design calculation to establish whether or not the building will be able to withstand the (extra) load at all times. Where necessary, modifications need to be made by you. Van der Valk will not accept any form of liability upon you not having obtained and used such a required design calculation.

Mounting systems for PV-panels placed on flat roofs should either be mechanically attached to the roof or need to be supported by ballast, to make sure that the solar mounting system is unable to be lifted, tipped over or slide. The required ballast weight per system shown in the tables in this manual ensures that the mounting system can be installed and used safely. In case the inclination of the roofs is 5 degrees or more, the PV-mounting system must always be mechanically fixed to the construction of the roof.

The calculations do not take into account obstacles in the near surrounding such as, for example, high buildings, cliffs and mountains. Restrictions also apply for the position of the solar mounting system on a roof. The solar panels must be installed at a certain distance from the edge of the roof: the middle zone.

The standard warranty is 10 years, which can be extended under certain conditions. The guarantee provided is subject to the guarantee conditions stated in the general terms and conditions stipulated by Van der Valk Solar Systems B.V. Our terms and conditions shall apply to all our products at all times and can be found on our website:

www.valksolarsystems.com

Van der Valk Solar Systems B.V. does not accept any liability for any direct and/or indirect consequences of any act (or omission) ensuing from the information in or failure to observe the instructions provided in this installation manual. The use of the installation manual will at all times be subject to Dutch law.

Van der Valk Solar Systems holds the right to amend this document without further notice.

Required ballast

General

The ValkBox3 mounting system must be weighted down by tiles, which will be placed at positions G1 and G2. Start by choosing the wind area in which the system will be installed from the overview below. Next, look at the table for the panel length in question. In this table, you will choose the relevant type of roof covering. Bitumen and EPDM have a higher skin friction and it will be possible to use less ballast for this type of roof covering. Next, choose the table for the wind area in question and the row for the building height applicable. This will show you the number of tiles necessary for positions G1 and G2.



The number of tiles calculated in the tables below are based on standard tiles measuring 30 x 30 x 4.5 cm and weighing 9 kg. If you are using tiles with different dimensions and, because of this, a different weight, you will need to add tiles until you have reached the weight required.

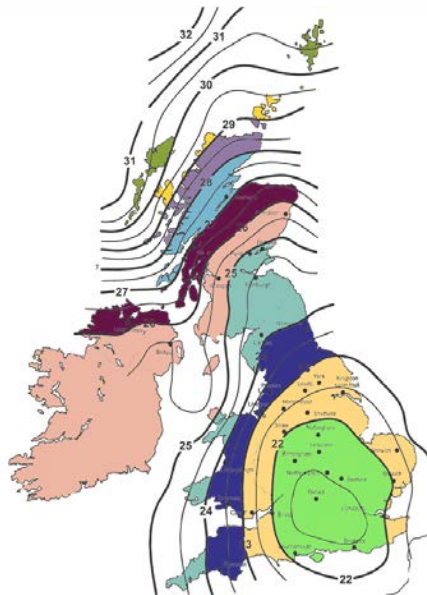

Selection table:

Minimum number of tiles per position G1 and G2 based on:

- Tile dimensions: 30 x 30 x 4,5 cm
- Tile weight: 9 kg
- Terrain category: town (sites more than 1 km inside town boundary - area where at least 15% of the surface is covered with buildings with an average height above 15m)
- Distance to shoreline: >10km
- Maximum height above sea level: <100m

Panel height approx. 180 cm (width 100 - 110 cm)			
Bitumen + EPDM		Concrete	
Position		Position	
Total G1	Total G2	Total G1	Total G2

Wind speed	Building height	Total G1	Total G2	Total G1	Total G2
21,5 m/s	0-5 meter	5 kg	61 kg	9 kg	70 kg
	5-10 meter	13 kg	83 kg	17 kg	83 kg
22 m/s	0-5 meter	7 kg	65 kg	11 kg	65 kg
	5-10 meter	14 kg	88 kg	19 kg	88 kg
23 m/s	0-5 meter	9 kg	72 kg	13 kg	72 kg
	5-10 meter	17 kg	97 kg	22 kg	97 kg
24 m/s	0-5 meter	12 kg	79 kg	16 kg	95 kg
	5-10 meter	20 kg	107 kg	26 kg	107 kg

Safety instructions

The ValkBox3 mounting system is installed on roofs and will be exposed to wind and snow. The building in question will be subject to a greater load as a result of the PV system. A design calculation must be used to establish whether or not the building in question will be able to withstand the extra load. Where necessary, modifications will then need to be made.

When installing the ValkBox3 mounting system, the instructions provided in this user manual must be observed at all times. Read this manual carefully and keep it in a safe place. Also follow the instructions stated in the manuals for the other system components that form part of the overall PV system. All current structural, safety and building regulations must be observed. Van der Valk Solar Systems B.V. will never be liable for any direct and/or indirect intangible or consequential loss ensuing from or connected to the failure to observe the instructions provided in this manual.

Starting points

The following starting points apply for the ValkBox3 mounting system:

The standards applied (if applicable for specific solar mounting system)

NEN-EN 1990:	Eurocode – Basis of structural design
NEN-EN 1991-1-4:	Eurocode 1: Actions on structures - Part 1-4: General actions – Wind actions
NVN7250:	Solar energy systems – Integration in roofs and facades – Constructional aspects
BS EN 1991-1-4:	British Standard

Type of solar panel

The ValkBox3 mounting system is a universal mounting system for solar panels. The following starting points apply:

Design panels:	Standard solar panels with an aluminium frame, with mounting holes for M6 bolts.
Length panels:	approx. 180 cm
Width panels:	100 - 110 cm
Weight panels:	approx. 20 kg (length approx. 180 cm)

Type of roofs

The ValkBox3 mounting system can be used to mount panels on flat roofs. The following starting points apply:

Type of roof covering: bitumen, EPDM and concrete

Before installing the ValkBox3 mounting system, make sure that you carefully sweep the roof area. The ballast calculation for the ValkBox3 mounting system (see later in this manual) only applies for flat roofs and roofs with a slight pitch of up to 5°. Above this roof pitch, the system should be attached to the roof securely.



Ballast

The ValkBox3 mounting system needs to be supported by ballast, to make sure that the system is unable to move, lift or tip over. See later in this manual details of which ballast should be used for each type of solar panel, each country, each type of roof covering and for each building height (subject to a maximum of 10 m). The number of tiles specified (30 x 30 x 4.5 cm) per position will be vital to ensure that the mounting system can be used safely.



To achieve this, follow the required ballast instructions later in this manual.

Position

Restrictions also apply for the position of the system on a roof. The solar panels must be installed at a certain distance from the edge of the roof.



According to the current standard, NEN-EN 1991-1-4, this free edge zone is 1/5 of the height of the roof. So, if a roof is 6 meters high, a free edge zone of 120 cm will be necessary.

The guarantee provided is subject to the guarantee conditions stated in the general terms and conditions stipulated by Van der Valk Solar Systems BV. Our terms and conditions can be found on our website: www.valksolarsystems.com.

Required ballast | The Netherlands

General

The ValkBox3 mounting system must be reinforced by means of tiles, which must be placed on the indicated ballast foundations. In three steps you can easily calculate the required ballast;

- determine the wind area on the windmap
- choose the wind area and building height in the table
- you can now read the number of tiles / kg

Note 1: Min. extra ballast in G1 & G2 has to be 2 x 1 tile (2 x 9 kg).

Note 2: The ballast in G1 & G2 must be equally divided over the rubber ballast carriers.

Note 3: The max. of 20 tiles (4 in G1 and 16 in G2) can be placed for extra ballast (180 kg).

Environmental factors

Position	Middle zone roof
Terrain category	Built environment
Roofing materials	Bitumen

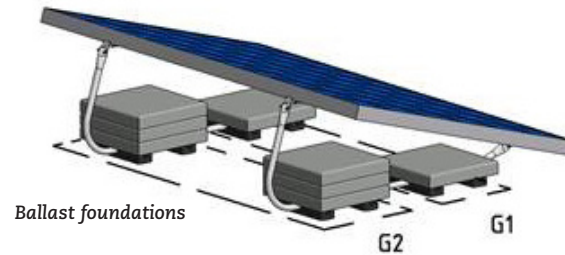

Windmap The Netherlands

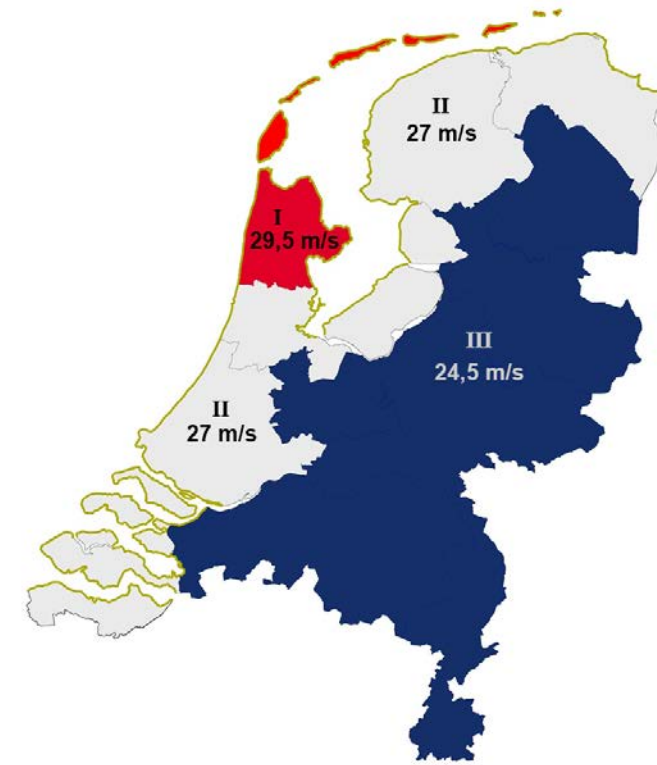

Panel: maximum dimensions 1800x1100 mm (21 kg)

Building height	0 - 5 meter		5 - 7 meter		7 - 9 meter		9 - 12 meter		12 - 15 meter		
	G1	G2	G1	G2	G1	G2	G1	G2	G1	G2	
I (29,5 m/s)	36,0	92,0	36,0	92,0	36,0	106,0	X	X	X	X	kg
	4,0	10,5	4,0	10,5	4,0	12,0	X	X	X	X	tiles
II (27 m/s)	36,0	73,0	36,0	73,0	36,0	85,0	36,0	98,0	36,0	X	kg
	4,0	8,5	4,0	8,5	4,0	9,5	4,0	11,0	4,0	X	tiles
III (24,5 m/s)	36,0	56,0	36,0	56,0	36,0	65,0	36,0	76,0	36,0	85,0	kg
	4,0	6,5	4,0	6,5	4,0	7,5	4,0	8,5	4,0	9,5	tiles

Panel: maximum dimensions 2100x1100 mm (24 kg)

Building height	0 - 5 meter		5 - 7 meter		7 - 9 meter		9 - 12 meter		12 - 15 meter		
	G1	G2	G1	G2	G1	G2	G1	G2	G1	G2	
I (29,5 m/s)	X	X	X	X	X	X	X	X	X	X	kg
	X	X	X	X	X	X	X	X	X	X	tiles
II (27 m/s)	36,0	88,0	36,0	88,0	36,0	101,0	X	X	X	X	kg
	4,0	10,0	4,0	10,0	4,0	11,5	X	X	X	X	tiles
III (24,5 m/s)	36,0	67,0	36,0	67,0	36,0	78,0	36,0	91,0	36,0	102,0	kg
	4,0	7,5	4,0	7,5	4,0	9,0	4,0	10,5	4,0	11,5	tiles

X = the required ballast is higher than will fit under the system. The system must be mechanically attached to the roof. Please contact Van der Valk Solar Systems.

* If you use tiles of different sizes and thus another weight, you need to adjust the number of tiles to get the right weight.

Required ballast | Belgium

General

The ValkBox3 mounting system must be reinforced by means of tiles, which must be placed on the indicated ballast foundations. In three steps you can easily calculate the required ballast;

- determine the wind area on the windmap
- choose the wind area and building height in the table
- you can now read the number of tiles / kg

Note 1: Min. extra ballast in G1 & G2 has to be 2 x 1 tile (2 x 9 kg).

Note 2: The ballast in G1 & G2 must be equally divided over the rubber ballast carriers.

Note 3: The max. of 20 tiles (4 in G1 and 16 in G2) can be placed for extra ballast (180 kg).

Environmental factors

Position	Middle zone roof
Terrain category	III (villages, suburban terrain, permanent forest)
Roofing materials	Bitumen

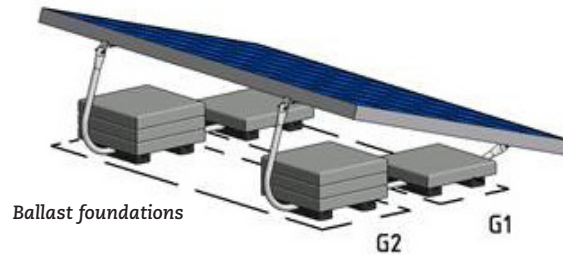

Windmap Belgium

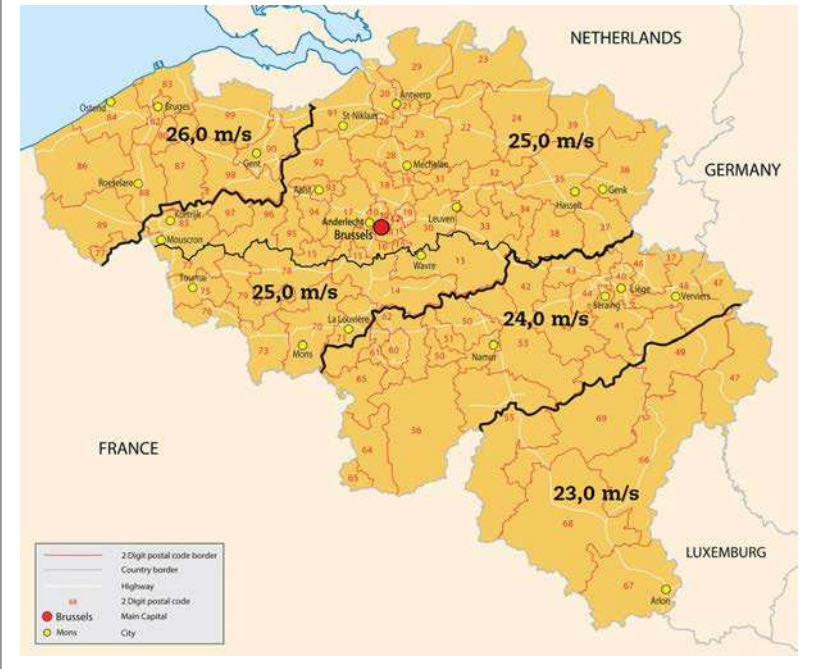

Panel: maximum dimensions 1800x1100 mm (21 kg)

Building height	0 - 5 meter		5 - 7 meter		7 - 9 meter		9 - 12 meter		12 - 15 meter		
	G1	G2	G1	G2	G1	G2	G1	G2	G1	G2	
23 m/s	36,0	38,0	36,0	47,0	36,0	54,0	36,0	63,0	36,0	69,0	kg
	4,0	4,5	4,0	5,5	4,0	6,0	4,0	7,0	4,0	8,0	tiles
24 m/s	36,0	43,0	36,0	53,0	36,0	61,0	36,0	70,0	36,0	77,0	kg
	4,0	5,0	4,0	6,0	4,0	7,0	4,0	8,0	4,0	9,0	tiles
25 m/s	36,0	48,0	36,0	59,0	36,0	67,0	36,0	78,0	36,0	86,0	kg
	4,0	5,5	4,0	7,0	4,0	7,5	4,0	9,0	4,0	10,0	tiles
26 m/s	36,0	54,0	36,0	65,0	36,0	75,0	36,0	85,0	36,0	94,0	kg
	4,0	6,0	4,0	7,5	4,0	8,5	4,0	9,5	4,0	10,5	tiles

Panel: maximum dimensions 2100x1100 mm (24 kg)

Building height	0 - 5 meter		5 - 7 meter		7 - 9 meter		9 - 12 meter		12 - 15 meter		
	G1	G2	G1	G2	G1	G2	G1	G2	G1	G2	
23 m/s	36,0	46,0	36,0	57,0	36,0	65,0	36,0	75,0	36,0	83,0	kg
	4,0	5,5	4,0	6,5	4,0	7,5	4,0	8,5	4,0	9,5	tiles
24 m/s	36,0	52,0	36,0	64,0	36,0	73,0	36,0	84,0	36,0	93,0	kg
	4,0	6,0	4,0	7,5	4,0	8,5	4,0	9,5	4,0	10,5	tiles
25 m/s	36,0	59,0	36,0	71,0	36,0	81,0	36,0	93,0	36,0	102,0	kg
	4,0	7,0	4,0	8,0	4,0	9,0	4,0	10,5	4,0	11,5	tiles
26 m/s	36,0	65,0	36,0	79,0	36,0	89,0	36,0	102,0	X	X	kg
	4,0	7,5	4,0	9,0	4,0	10,0	4,0	11,5	X	X	tiles

X = the required ballast is higher than will fit under the system. The system must be mechanically attached to the roof. Please contact Van der Valk Solar Systems.

* If you use tiles of different sizes and thus another weight, you need to adjust the number of tiles to get the right weight.

Required ballast | Germany

General

The ValkBox3 mounting system must be reinforced by means of tiles, which must be placed on the indicated ballast foundations. In three steps you can easily calculate the required ballast;

- determine the wind area on the windmap
- choose the wind area and building height in the table
- you can now read the number of tiles / kg

Note 1: Min. extra ballast in G1 & G2 has to be 2 x 1 tile (2 x 9 kg).

Note 2: The ballast in G1 & G2 must be equally divided over the rubber ballast carriers.

Note 3: The max. of 20 tiles (4 in G1 and 16 in G2) can be placed for extra ballast (180 kg).

Environmental factors

Position	Middle zone roof
Terrain category	IV (city)
Height above sea level	350 m
Exclusief North German Lowland	
Roof materials	Bitumen

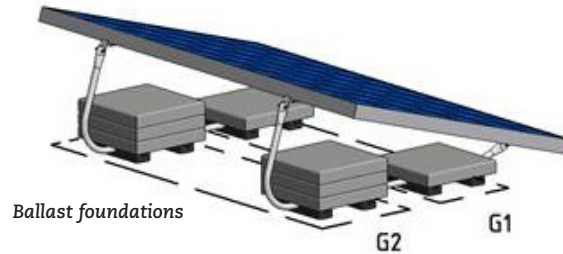

Windmap Germany

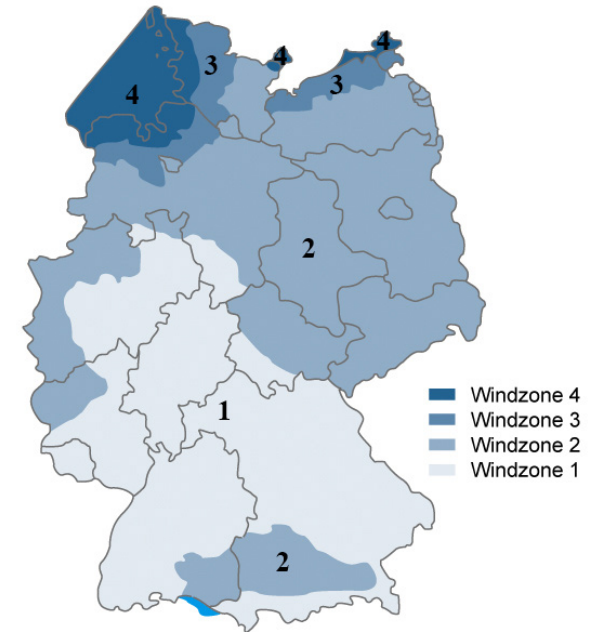

Panel: maximum dimensions 1800x1100 mm (21 kg)

Building height	0 - 5 meter		5 - 7 meter		7 - 9 meter		9 - 12 meter		12 - 15 meter		
	G1	G2	G1	G2	G1	G2	G1	G2	G1	G2	
1 (22,5 m/s)	36,0	39,0	36,0	39,0	36,0	39,0	36,0	39,0	36,0	39,0	kg
	4,0	8,7	4,0	4,5	4,0	4,5	4,0	4,5	4,0	4,5	tiles
2 (25 m/s)	36,0	53,0	36,0	53,0	36,0	53,0	36,0	53,0	36,0	53,0	kg
	4,0	6,0	4,0	6,0	4,0	6,0	4,0	6,0	4,0	6,0	tiles
3 (27,5 m/s)	36,0	68,0	36,0	68,0	36,0	68,0	36,0	68,0	36,0	68,0	kg
	4,0	8,0	4,0	8,0	4,0	8,0	4,0	8,0	4,0	8,0	tiles
4 (30 m/s)	36,0	84,0	36,0	84,0	36,0	84,0	36,0	84,0	36,0	84,0	kg
	4,0	9,5	4,0	9,5	4,0	9,5	4,0	9,5	4,0	9,5	tiles

Panel: maximum dimensions 2100x1100 mm (24 kg)

Building height	0 - 5 meter		5 - 7 meter		7 - 9 meter		9 - 12 meter		12 - 15 meter		
	G1	G2	G1	G2	G1	G2	G1	G2	G1	G2	
1 (22,5 m/s)	36,0	48,0	36,0	48,0	36,0	48,0	36,0	48,0	36,0	48,0	kg
	4,0	5,5	4,0	5,5	4,0	5,5	4,0	5,5	4,0	5,5	tiles
2 (25 m/s)	36,0	64,0	36,0	64,0	36,0	64,0	36,0	64,0	36,0	64,0	kg
	4,0	7,5	4,0	7,5	4,0	7,5	4,0	7,5	4,0	7,5	tiles
3 (27,5 m/s)	36,0	81,0	36,0	81,0	36,0	81,0	36,0	81,0	36,0	81,0	kg
	4,0	9,0	4,0	9,0	4,0	9,0	4,0	9,0	4,0	9,0	tiles
4 (30 m/s)	36,0	100,0	36,0	100,0	36,0	100,0	36,0	100,0	36,0	100,0	kg
	4,0	11,5	4,0	11,5	4,0	11,5	4,0	11,5	4,0	11,5	tiles

X = the required ballast is higher than will fit under the system. The system must be mechanically attached to the roof. Please contact Van der Valk Solar Systems.

* If you use tiles of different sizes and thus another weight, you need to adjust the number of tiles to get the right weight.

Required ballast | United Kingdom

General

The ValkBox3 mounting system must be reinforced by means of tiles, which must be placed on the indicated ballast foundations. In three steps you can easily calculate the required ballast;

- determine the wind area on the windmap
- choose the wind area and building height in the table
- you can now read the number of tiles / kg

Note 1: Min. extra ballast in G1 & G2 has to be 2 x 1 tile (2 x 9 kg).

Note 2: The ballast in G1 & G2 must be equally divided over the rubber ballast carriers.

Note 3: The max. of 20 tiles (4 in G1 and 16 in G2) can be placed for extra ballast (180 kg).

Environmental factors

Position	Middle zone roof
Terrain category	Built environment
Height above sea level	50 m
Distance to coast line	5 km
Distance to city border	5 km
Roof materials	Bitumen

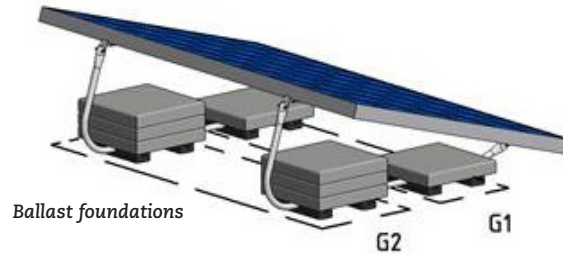

Windmap United Kingdom

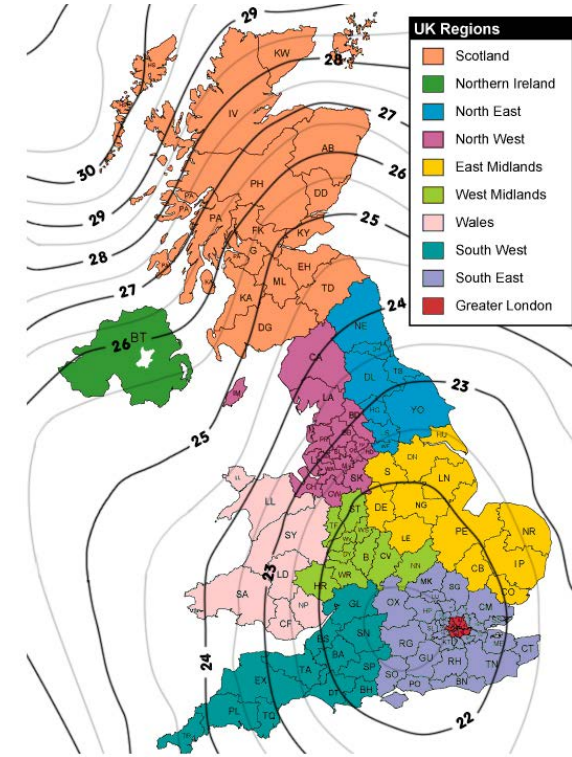

Panel: maximum dimensions 1800x1100 mm (21 kg)

Building height	0 - 5 meter		5 - 7 meter		7 - 9 meter		9 - 12 meter		12 - 15 meter		
	G1	G2	G1	G2	G1	G2	G1	G2	G1	G2	
22 m/s	36,0	57,0	36,0	72,0	36,0	78,0	36,0	97,0	36,0	97,0	kg
	4,0	6,5	4,0	8,0	4,0	9,0	4,0	11,0	4,0	11,0	tiles
23 m/s	36,0	64,0	36,0	81,0	36,0	87,0	36,0	108,0	36,0	108,0	kg
	4,0	7,5	4,0	9,0	4,0	10,0	4,0	12,0	4,0	12,0	tiles
24 m/s	36,0	71,0	36,0	89,0	36,0	97,0	X	X	X	X	kg
	4,0	8,0	4,0	10,0	4,0	11,0	X	X	X	X	tiles
25 m/s	36,0	79,0	36,0	99,0	36,0	107,0	X	X	X	X	kg
	4,0	9,0	4,0	11,0	4,0	12,0	X	X	X	X	tiles
26 m/s	36,0	87,0	36,0	108,0	X	X	X	X	X	X	kg
	4,0	10,0	4,0	12,0	X	X	X	X	X	X	tiles

Panel: maximum dimensions 2100x1100 mm (24 kg)

Building height	0 - 5 meter		5 - 7 meter		7 - 9 meter		9 - 12 meter		12 - 15 meter		
	G1	G2	G1	G2	G1	G2	G1	G2	G1	G2	
22 m/s	36,0	68,0	36,0	86,0	36,0	94,0	X	X	X	X	kg
	4,0	8,0	4,0	10,0	4,0	10,5	X	X	X	X	tiles
23 m/s	36,0	77,0	36,0	96,0	36,0	104,0	X	X	X	X	kg
	4,0	9,0	4,0	11,0	4,0	12,0	X	X	X	X	tiles
24 m/s	36,0	85,0	36,0	107,0	X	X	X	X	X	X	kg
	4,0	9,5	4,0	12,0	X	X	X	X	X	X	tiles
25 m/s	36,0	94,0	X	X	X	X	X	X	X	X	kg
	4,0	10,5	X	X	X	X	X	X	X	X	tiles
26 m/s	36,0	104,0	X	X	X	X	X	X	X	X	kg
	4,0	12,0	X	X	X	X	X	X	X	X	tiles

X = the required ballast is higher than will fit under the system. The system must be mechanically attached to the roof. Please contact Van der Valk Solar Systems.

* If you use tiles of different sizes and thus another weight, you need to adjust the number of tiles to get the right weight.

Required ballast | Norway

General

The ValkBox3 mounting system must be reinforced by means of tiles, which must be placed on the indicated ballast foundations. In three steps you can easily calculate the required ballast;

- determine the wind area on the windmap
- choose the wind area and building height in the table
- you can now read the number of tiles / kg

Note 1: Min. extra ballast in G1 & G2 has to be 2 x 1 tile (2 x 9 kg).

Note 2: The ballast in G1 & G2 must be equally divided over the rubber ballast carriers.

Note 3: The max. of 20 tiles (4 in G1 and 16 in G2) can be placed for extra ballast (180 kg).

Environmental factors

Position	Middle zone roof
Terrain category	III (villages, suburban terrain, permanent forest)
Height above sea level	175 m
Roofing materials	Bitumen

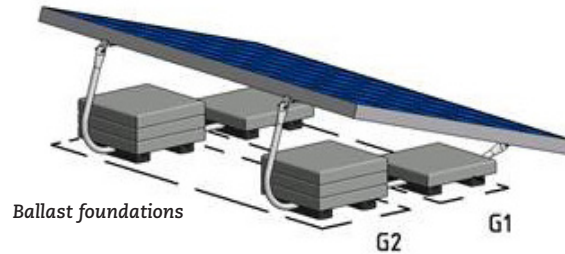

Windmap Norway



For determining the wind area see next page.

Panel: maximum dimensions 1800x1100 mm (21 kg)

Building height	0 - 5 meter		5 - 7 meter		7 - 9 meter		9 - 12 meter		12 - 15 meter		
Wind area	G1	G2	G1	G2	G1	G2	G1	G2	G1	G2	
22 m/s	36,0	50,0	36,0	50,0	36,0	53,0	36,0	61,0	36,0	68,0	kg
	4,0	6,0	4,0	6,0	4,0	6,0	4,0	7,0	4,0	8,0	tiles
25 m/s	36,0	70,0	36,0	70,0	36,0	74,0	36,0	85,0	36,0	93,0	kg
	4,0	8,0	4,0	8,0	4,0	8,5	4,0	9,5	4,0	10,5	tiles
27 m/s	36,0	85,0	36,0	85,0	36,0	90,0	36,0	102,0	X	X	kg
	4,0	9,5	4,0	9,5	4,0	10,0	4,0	11,5	X	X	tiles
29 m/s	36,0	101,0	36,0	101,0	36,0	106,0	X	X	X	X	kg
	4,0	11,5	4,0	11,5	4,0	12,0	X	X	X	X	tiles
31 m/s	X	X	X	X	X	X	X	X	X	X	kg
	X	X	X	X	X	X	X	X	X	X	tiles

Panel: maximum dimensions 2100x1100 mm (24 kg)

Building height	0 - 5 meter		5 - 7 meter		7 - 9 meter		9 - 12 meter		12 - 15 meter		
Wind area	G1	G2	G1	G2	G1	G2	G1	G2	G1	G2	
22 m/s	36,0	60,0	36,0	60,0	36,0	64,0	36,0	74,0	36,0	81,0	kg
	4,0	7,0	4,0	7,0	4,0	7,5	4,0	8,5	4,0	9,0	tiles
25 m/s	36,0	84,0	36,0	84,0	36,0	89,0	36,0	101,0	X	X	kg
	4,0	9,5	4,0	9,5	4,0	10,0	4,0	11,5	X	X	tiles
27 m/s	36,0	101,0	36,0	101,0	36,0	107,0	X	X	X	X	kg
	4,0	11,5	4,0	11,5	4,0	12,0	X	X	X	X	tiles
29 m/s	X	X	X	X	X	X	X	X	X	X	kg
	X	X	X	X	X	X	X	X	X	X	tiles
31 m/s	X	X	X	X	X	X	X	X	X	X	kg
	X	X	X	X	X	X	X	X	X	X	tiles

X = the required ballast is higher than will fit under the system. The system must be mechanically attached to the roof. Please contact Van der Valk Solar Systems.

* If you use tiles of different sizes and thus another weight, you need to adjust the number of tiles to get the right weight.

Wind area | Norway

	m/s		m/s		m/s		m/s		m/s		m/s
Provincie Østfold	22	Nore og Uvdal	24	Sokndal	27	Flora	28	Provincie Nord-Trøndelag	26	Provincie Troms	26
<i>Except Municipalities:</i>		Nore og Uvdal near Hordeland	24	Bokn	28	Gulen	28	<i>Except Municipalities:</i>		<i>Except Municipalities:</i>	
Halden	24	Ål	24	Haugesund	28	Bremanger	29	Lierne	24	Bardu	24
Moss	24	Ål near Sogn og Fj.	24	Klepp	28	Bremanger near the Ålfotbreen	29	Meråker	25	Målselv	24
Rygge	24	Provincie Vestfold	23	Randaberg	28	Solund	29	Røyrvik	25	Stroffjord	24
Råde	24	<i>Except Municipalities:</i>		Rennesøy	28	Selje	31	Snåsa	25	Gáivuona/Káfjord	25
Sarpsborg	24	Hof	22	Sola	28	Vågsøy	31	Flatanger	29	Balsfjord	26
Våler	24	Lardal	22	Time	28	Provincie Møre og Romsdal	30	Fosnes	29	Gratangen	26
Fredrikstad	26	Nøtterøy	24	Hå	29	<i>Except Municipalities:</i>		Leka	29	Ibestad	26
Hvaler	27	Sandefjord	24	Kvitsøy	29	Rindal	25	Leka on the mainland	29	Lavangen	26
Provincie Akershus	22	Stokke	24	Karmøy	30	Surmadal	25	Nærøy	29	Lyngen	26
<i>Except Municipality:</i>		Tønsberg	24	Utsira	30	Neset	26	Vikna	30	Salangen	26
Vestby	24	Larvik	25	Ølen		Norddal	26	Provincie Nordland	29	Skånland	26
Provincie Oslo	22	Tjøme	26		<i>Municipality isn't in the Wind standard</i>	Stordal	26	<i>Except Municipalities:</i>		Sørreisa	26
Provincie Hedmark	22	Provincie Telemark	22	Provincie Hordaland	26	Stranda	26	Beiam	26	Dyrøy	27
<i>Except Municipalities:</i>		<i>Except Municipalities:</i>		<i>Except Municipalities:</i>		Sunndal	27	Evenes	26	Harstad	27
Alvdal	24	Bamble	23	Etne	24	Gjemnes	28	Fauske	26	Lenvik	27
Folldal	24	Porsgrunn	23	Etne near the Folgefonna	24	Rauma	28	Grane	26	Nordreisa	27
Folldal near Trøndelag	24	Fyresdal	24	Granvin	24	Sykkylven	28	Hattfjelldal	26	Tranøy	27
Os	24	Kragerø	24	Kvam	24	Tingvoll	28	Hemnes	26	Tromsø	27
Os near Trøndelag	24	Tinn	24	Modalen	24	Volda	28	Rana	26	Bjarkøy	28
Tolga	24	Tokke	24	Samnanger	24	Ørskog	28	Saltedal	26	Kvænangen	28
Tynset	24	Vinje	24	Ulvik	24	Ørsta	28	Sørfold	26	Skjervøy	28
Tynset Kvikne	24	Vinje near Rogaland/Hordaland	24	Vaksdal	24	Eide	29	Ballangen	27	Karlsøy	29
Tynset near Trøndelag	24	Provincie Aust-Agder	24	Voss	24	Halsa	29	Tjeldsund	27	Berg	30
Provincie Oppland	22	<i>Except Municipalities:</i>		Osterøy	25	Hareid	29	Tysfjord	27	Torsken	30
<i>Except Municipalities:</i>		Arendal	26	Radøy	27	Molde	29	Hamarøy	28	Provincie Finnmark	29
Vågå	23	Grimstad	26	Austevoll	28	Skodje	29	Narvik	28	<i>Except Municipalities:</i>	
Dovre	24	Lillesand	26	Austrheim	28	Sula	29	Sortland	28	Karájoga / Karasjok	24
Dovre near Trøndelag	24	Risør	26	Bømlo	28	Ålesund	29	Vefsn	28	Guovdageaidnu / Kautokeino	24
Lom	24	Tvedestrand	26	Fjell	28	Sandøy	31	Vefsn along the fjord	28	Deanu/Tana	27
Lom near Sogn og Fj.	24	Provincie Vest-Agder	24	Sund	28	Frei		Vefsn Mosjøen	28	Porsanger	27
Vang	24	<i>Except Municipalities:</i>		Øygarden	29		<i>Municipality isn't in the Wind standard</i>	Vevelstad	28	Unjárgga / Nesseby	27
Vang near Sogn og Fj.	24	Arendal	26	Fedje	30	Tustna		Alstahaug	30	Alta	28
Lesja	25	Grimstad	26	Provincie Sogn og Fjordane	24		<i>Municipality isn't in the Wind standard</i>	Bindal	30	Berlevåg	30
Lesja near Trøndelag/		Lillesand	26	<i>Except Municipalities:</i>		Provincie Sør-Trøndelag	25	Bodø	30	Gamvik	30
Møre og Romsdal	25	Risør	26	Aurland	25	<i>Except Municipalities:</i>		Dønna	30	Hasvik	30
Skjåk	25	Tvedestrand	26	Eid	26	Malvik	26	Flakstad	30	Måsøy	30
Skjåk near Sogn og Fj./		Flekkefjord	26	Fjaler	26	Oppdal	26	Herøy	30	Nordkapp	30
Møre og Romsdal	25	Flekkefjord near Rogaland	26	Førde	26	Rennebu	26	Leirfjord	30	Vardø	30
Provincie Buskerud	22	Kristiansand	26	Førde near the Jostedalsbreen	26	Trondheim	26	Lurøy	30	Provincie Svalbard	30
<i>Except Municipalities:</i>		Lyngdal	26	Gaular	26	Agdenes	27	Lurøy on the mainland	30		
Hemsedal	24	Søngne	26	Gloppen	26	Rissa	27	Nesna	30		
Hemsedal near Sogn og Fj.	24	Farsund	28	Gloppen near the Ålfotbreen and		Snillfjord	27	Sømna	30		
Hol	24	Lindesnes	28	Jostedalsbreen	26	Hemne	28	Vega	30		
Hol near Hordeland /		Mandal	28	Hornindal	26	Bjugn	29	Vestvågøy	30		
Sogn og Fjordane	24	Provincie Rogaland	26	Hyllestad	26	Roan	29	Andøy	31		
Hurum	24	<i>Except Municipalities:</i>		Høyanger	26	Åfjord	29	Moskenes	31		
		Suldal	24	Lærdal	26	Frøya	30	Røst	31		
		Vindafjord	24	Naustdal	26	Hitra	30	Træna	31		
		Eigersund	27	Askvoll	28	Ørland	30	Værøy	31		
								Skjerstad			
								<i>Municipality isn't in the Wind standard</i>			

Required ballast | Sweden

General

The ValkBox3 mounting system must be reinforced by means of tiles, which must be placed on the indicated ballast foundations. In three steps you can easily calculate the required ballast;

- determine the wind area on the windmap
- choose the wind area and building height in the table
- you can now read the number of tiles / kg

Note 1: Min. extra ballast in G1 & G2 has to be 2 x 1 tile (2 x 9 kg).

Note 2: The ballast in G1 & G2 must be equally divided over the rubber ballast carriers.

Note 3: The max. of 20 tiles (4 in G1 and 16 in G2) can be placed for extra ballast (180 kg).

Environmental factors

Position	Middle zone roof
Terrain category	III (villages, suburban terrain, permanent forest)
Roofing materials	Bitumen

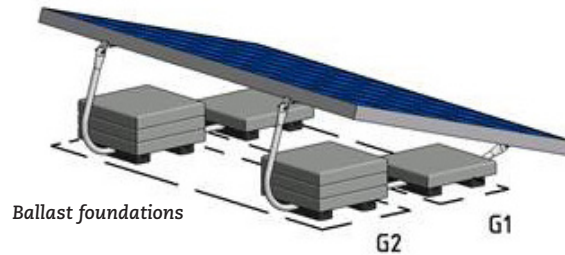

Panel: maximum dimensions 1800x1100 mm (21 kg)

Building height	0 - 5 meter		5 - 7 meter		7 - 9 meter		9 - 12 meter		12 - 15 meter		
	G1	G2	G1	G2	G1	G2	G1	G2	G1	G2	
22 m/s	36,0	27,0	36,0	35,0	36,0	41,0	36,0	48,0	36,0	54,0	kg
	4,0	3,0	4,0	4,0	4,0	5,0	4,0	5,5	4,0	6,0	tiles
23 m/s	36,0	32,0	36,0	40,0	36,0	46,0	36,0	54,0	36,0	60,0	kg
	4,0	4,0	4,0	4,5	4,0	5,5	4,0	6,0	4,0	7,0	tiles
24 m/s	36,0	36,0	36,0	45,0	36,0	52,0	36,0	61,0	36,0	68,0	kg
	4,0	4,0	4,0	5,0	4,0	6,0	4,0	7,0	4,0	8,0	tiles
25 m/s	36,0	41,0	36,0	51,0	36,0	58,0	36,0	68,0	36,0	75,0	kg
	4,0	5,0	4,0	6,0	4,0	6,5	4,0	8,0	4,0	8,5	tiles
26 m/s	36,0	46,0	36,0	56,0	36,0	65,0	36,0	75,0	36,0	83,0	kg
	4,0	5,5	4,0	6,5	4,0	7,5	4,0	8,5	4,0	9,5	tiles

Panel: maximum dimensions 2100x1100 mm (24 kg)

Building height	0 - 5 meter		5 - 7 meter		7 - 9 meter		9 - 12 meter		12 - 15 meter		
	G1	G2	G1	G2	G1	G2	G1	G2	G1	G2	
22 m/s	36,0	34,0	36,0	43,0	36,0	50,0	36,0	58,0	36,0	65,0	kg
	4,0	4,0	4,0	5,0	4,0	6,0	4,0	6,5	4,0	7,5	tiles
23 m/s	36,0	39,0	36,0	49,0	36,0	56,0	36,0	66,0	36,0	73,0	kg
	4,0	4,5	4,0	5,5	4,0	6,5	4,0	7,5	4,0	8,5	tiles
24 m/s	36,0	45,0	36,0	55,0	36,0	63,0	36,0	73,0	36,0	81,0	kg
	4,0	5,0	4,0	6,5	4,0	7,0	4,0	8,5	4,0	9,0	tiles
25 m/s	36,0	50,0	36,0	61,0	36,0	70,0	36,0	81,0	36,0	90,0	kg
	4,0	6,0	4,0	7,0	4,0	8,0	4,0	9,0	4,0	10,0	tiles
26 m/s	36,0	56,0	36,0	68,0	36,0	78,0	36,0	89,0	36,0	99,0	kg
	4,0	6,5	4,0	8,0	4,0	9,0	4,0	10,0	4,0	11,0	tiles

Windmap Sweden



X = the required ballast is higher than will fit under the system. The system must be mechanically attached to the roof. Please contact Van der Valk Solar Systems.

* If you use tiles of different sizes and thus another weight, you need to adjust the number of tiles to get the right weight.

Required ballast | Finland

General

The ValkBox3 mounting system must be reinforced by means of tiles, which must be placed on the indicated ballast foundations. In three steps you can easily calculate the required ballast;

- determine the wind area on the windmap
- choose the wind area and building height in the table
- you can now read the number of tiles / kg

Note 1: Min. extra ballast in G1 & G2 has to be 2 x 1 tile (2 x 9 kg).

Note 2: The ballast in G1 & G2 must be equally divided over the rubber ballast carriers.

Note 3: The max. of 20 tiles (4 in G1 and 16 in G2) can be placed for extra ballast (180 kg).

Environmental factors

Position	Middle zone roof
Terrain category	III (villages, suburban terrain, permanent forest)
Roofing materials	Bitumen

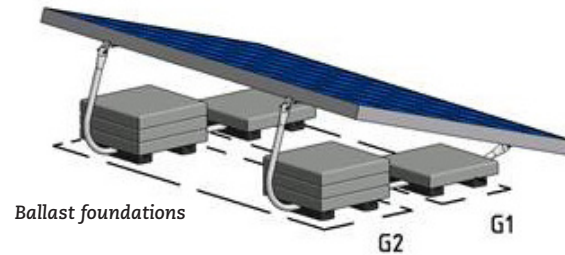

Windmap Finland

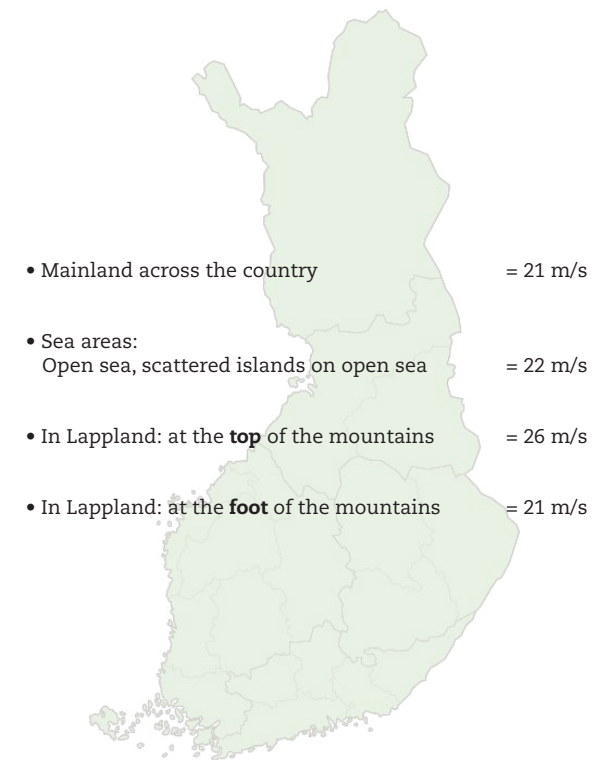

Panel: maximum dimensions 1800x1100 mm (21 kg)

Building height	0 - 5 meter		5 - 7 meter		7 - 9 meter		9 - 12 meter		12 - 15 meter		
	G1	G2	G1	G2	G1	G2	G1	G2	G1	G2	
21 m/s	36,0	38,0	36,0	47,0	36,0	54,0	36,0	62,0	36,0	69,0	kg
	4,0	4,5	4,0	5,5	4,0	6,0	4,0	7,0	4,0	8,0	tiles
22 m/s	36,0	43,0	36,0	53,0	36,0	61,0	36,0	70,0	36,0	78,0	kg
	4,0	5,0	4,0	6,0	4,0	7,0	4,0	8,0	4,0	9,0	tiles
26 m/s	36,0	68,0	36,0	82,0	36,0	93,0	36,0	106,0	X	X	kg
	4,0	8,0	4,0	9,5	4,0	10,5	4,0	12,0	X	X	tiles

Panel: maximum dimensions 2100x1100 mm (24 kg)

Building height	0 - 5 meter		5 - 7 meter		7 - 9 meter		9 - 12 meter		12 - 15 meter		
	G1	G2	G1	G2	G1	G2	G1	G2	G1	G2	
21 m/s	36,0	46,0	36,0	57,0	36,0	65,0	36,0	75,0	36,0	83,0	kg
	4,0	5,5	4,0	6,5	4,0	7,5	4,0	8,5	4,0	9,5	tiles
22 m/s	36,0	53,0	36,0	64,0	36,0	73,0	36,0	84,0	36,0	93,0	kg
	4,0	6,0	4,0	7,5	4,0	8,5	4,0	9,5	4,0	10,5	tiles
26 m/s	36,0	82,0	36,0	98,0	X	X	X	X	X	X	kg
	4,0	9,5	4,0	11,0	X	X	X	X	X	X	tiles

X = the required ballast is higher than will fit under the system. The system must be mechanically attached to the roof. Please contact Van der Valk Solar Systems.

* If you use tiles of different sizes and thus another weight, you need to adjust the number of tiles to get the right weight.

Required ballast | Poland

General

The ValkBox3 mounting system must be reinforced by means of tiles, which must be placed on the indicated ballast foundations. In three steps you can easily calculate the required ballast;

- determine the wind area on the windmap
- choose the wind area and building height in the table
- you can now read the number of tiles / kg

Note 1: Min. extra ballast in G1 & G2 has to be 2 x 1 tile (2 x 9 kg).

Note 2: The ballast in G1 & G2 must be equally divided over the rubber ballast carriers.

Note 3: The max. of 20 tiles (4 in G1 and 16 in G2) can be placed for extra ballast (180 kg).

Environmental factors

Position	Middle zone roof
Terrain category	III (villages, suburban terrain, permanent forest)
Roofing materials	Bitumen

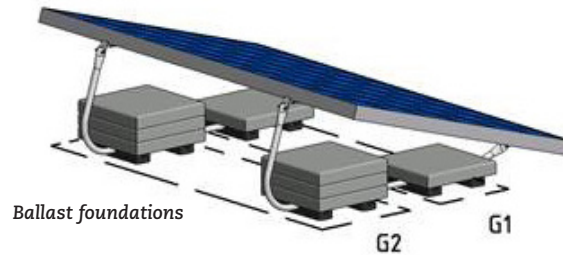

Windmap Poland

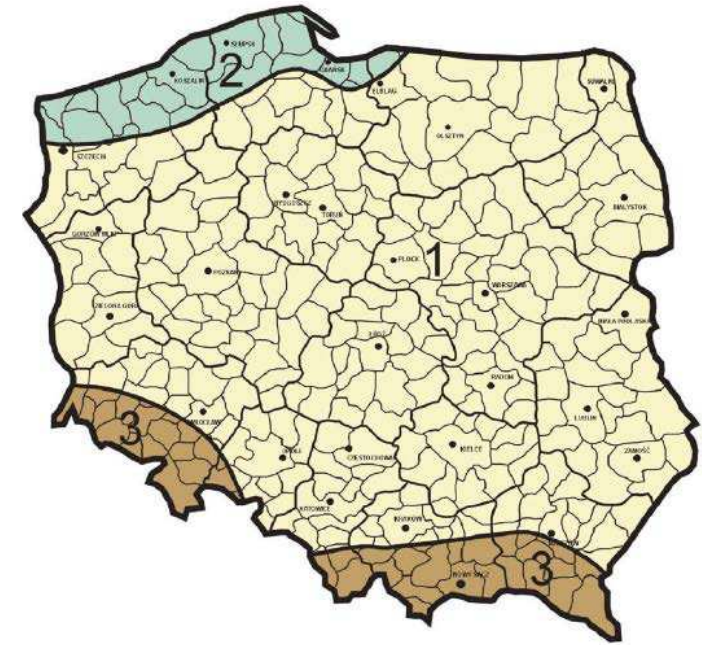

Panel: maximum dimensions 1800x1100 mm (21 kg)

Building height	0 - 5 meter		5 - 7 meter		7 - 9 meter		9 - 12 meter		12 - 15 meter		
	G1	G2	G1	G2	G1	G2	G1	G2	G1	G2	
1	36,0	50,0	36,0	57,0	36,0	62,0	36,0	68,0	36,0	74,0	kg
	4,0	6,0	4,0	6,5	4,0	7,0	4,0	8,0	4,0	85,0	tiles
2	36,0	78,0	36,0	87,0	36,0	94,0	36,0	103,0	X	X	kg
	4,0	9,0	4,0	10,0	4,0	10,5	4,0	11,5	X	X	tiles
3	36,0	50,0	36,0	57,0	36,0	62,0	36,0	68,0	36,0	74,0	kg
	4,0	6,0	4,0	6,5	4,0	7,0	4,0	8,0	4,0	85,0	tiles

Panel: maximum dimensions 2100x1100 mm (24 kg)

Building height	0 - 5 meter		5 - 7 meter		7 - 9 meter		9 - 12 meter		12 - 15 meter		
	G1	G2	G1	G2	G1	G2	G1	G2	G1	G2	
1	36,0	60,0	36,0	60,0	36,0	64,0	36,0	74,0	36,0	81,0	kg
	4,0	7,0	4,0	7,0	4,0	7,5	4,0	8,5	4,0	9,0	tiles
2	36,0	84,0	36,0	84,0	X	X	X	X	X	X	kg
	4,0	9,5	4,0	9,5	X	X	X	X	X	X	tiles
3	36,0	101,0	36,0	101,0	36,0	107,0	36,0	121,0	36,0	136,0	kg
	4,0	11,5	4,0	11,5	4,0	12,0	4,0	13,5	4,0	15,5	tiles

X = the required ballast is higher than will fit under the system. The system must be mechanically attached to the roof. Please contact Van der Valk Solar Systems.

* If you use tiles of different sizes and thus another weight, you need to adjust the number of tiles to get the right weight.

Required ballast | Spain

General

The ValkBox3 mounting system must be reinforced by means of tiles, which must be placed on the indicated ballast foundations. In three steps you can easily calculate the required ballast;

- determine the wind area on the windmap
- choose the wind area and building height in the table
- you can now read the number of tiles / kg

Note 1: Min. extra ballast in G1 & G2 has to be 2 x 1 tile (2 x 9 kg).

Note 2: The ballast in G1 & G2 must be equally divided over the rubber ballast carriers.

Note 3: The max. of 20 tiles (4 in G1 and 16 in G2) can be placed for extra ballast (180 kg).

Environmental factors

Position	Middle zone roof
Terrain category	III (villages, suburban terrain, permanent forest)
Height above sea level	< 1000 m
Roofing materials	Concrete

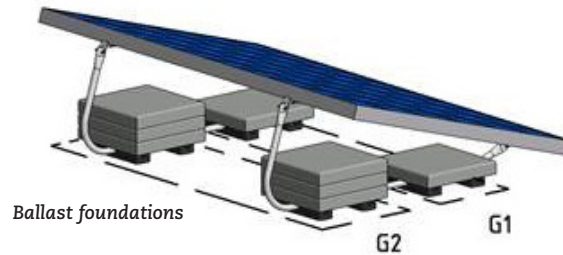

Windmap Spain

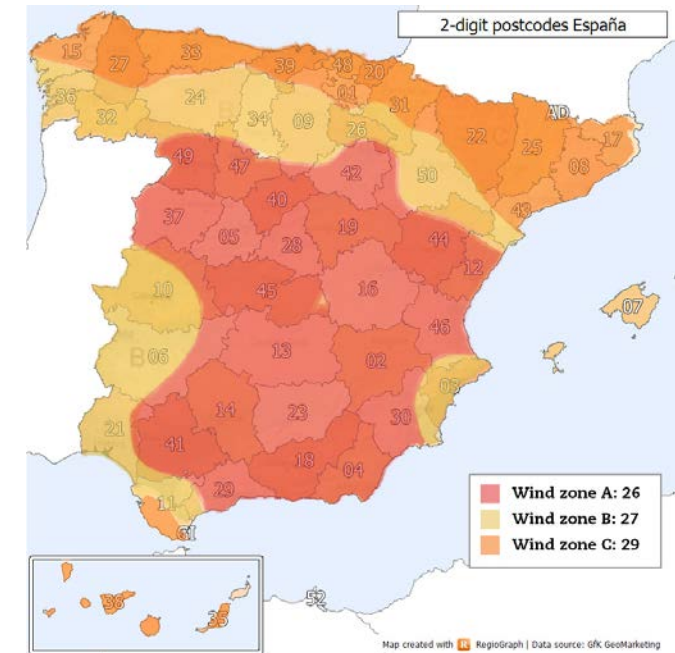

Panel: maximum dimensions 1800x1100 mm (21 kg)

Building height	0 - 5 meter		5 - 7 meter		7 - 9 meter		9 - 12 meter		12 - 15 meter		
	G1	G2	G1	G2	G1	G2	G1	G2	G1	G2	
26 m/s	36,0	62,0	36,0	62,0	36,0	62,0	36,0	62,0	36,0	62,0	kg
	4,0	7,0	4,0	7,0	4,0	7,0	4,0	7,0	4,0	7,0	tiles
27 m/s	36,0	68,0	36,0	68,0	36,0	68,0	36,0	68,0	36,0	68,0	kg
	4,0	8,0	4,0	8,0	4,0	8,0	4,0	8,0	4,0	8,0	tiles
29 m/s	36,0	81,0	36,0	81,0	36,0	81,0	36,0	81,0	36,0	81,0	kg
	4,0	9,0	4,0	9,0	4,0	9,0	4,0	9,0	4,0	9,0	tiles

Panel: maximum dimensions 2100x1100 mm (24 kg)

Building height	0 - 5 meter		5 - 7 meter		7 - 9 meter		9 - 12 meter		12 - 15 meter		
	G1	G2	G1	G2	G1	G2	G1	G2	G1	G2	
26 m/s	36,0	74,0	36,0	74,0	36,0	74,0	36,0	74,0	36,0	74,0	kg
	4,0	8,5	4,0	8,5	4,0	8,5	4,0	8,5	4,0	8,5	tiles
27 m/s	36,0	82,0	36,0	82,0	36,0	82,0	36,0	82,0	36,0	82,0	kg
	4,0	9,5	4,0	9,5	4,0	9,5	4,0	9,5	4,0	9,5	tiles
29 m/s	36,0	97,0	36,0	97,0	36,0	97,0	36,0	97,0	36,0	97,0	kg
	4,0	11,0	4,0	11,0	4,0	11,0	4,0	11,0	4,0	11,0	tiles

X = the required ballast is higher than will fit under the system. The system must be mechanically attached to the roof. Please contact Van der Valk Solar Systems.

* If you use tiles of different sizes and thus another weight, you need to adjust the number of tiles to get the right weight.

Required ballast | Portugal

General

The ValkBox3 mounting system must be reinforced by means of tiles, which must be placed on the indicated ballast foundations. In three steps you can easily calculate the required ballast;

- determine the wind area on the windmap
- choose the wind area and building height in the table
- you can now read the number of tiles / kg

Note 1: Min. extra ballast in G1 & G2 has to be 2 x 1 tile (2 x 9 kg).

Note 2: The ballast in G1 & G2 must be equally divided over the rubber ballast carriers.

Note 3: The max. of 20 tiles (4 in G1 and 16 in G2) can be placed for extra ballast (180 kg).

Environmental factors

Position	Middle zone roof
Terrain category	III (villages, suburban terrain, permanent forest)
Height above sea level	< 1000 m
Roofing materials	Concrete

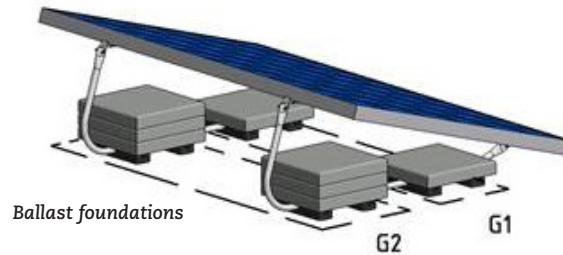

Windmap Portugal

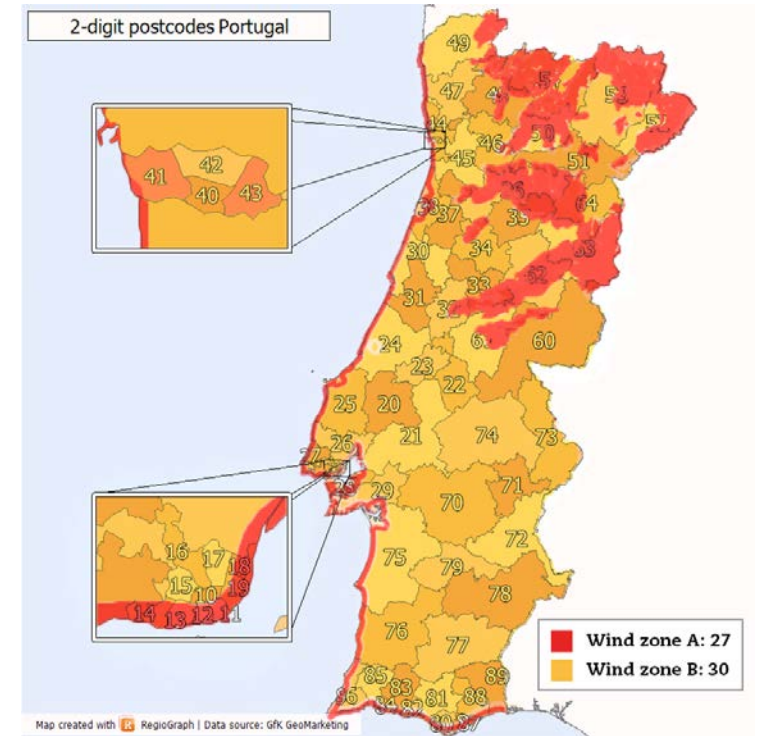

Panel: maximum dimensions 1800x1100 mm (21 kg)

Building height	0 - 5 meter		5 - 7 meter		7 - 9 meter		9 - 12 meter		12 - 15 meter		
	G1	G2	G1	G2	G1	G2	G1	G2	G1	G2	
27 m/s	36,0	68,0	36,0	68,0	36,0	68,0	36,0	68,0	36,0	68,0	kg
	4,0	8,0	4,0	8,0	4,0	8,0	4,0	8,0	4,0	8,0	tiles
30 m/s	36,0	89,0	36,0	89,0	36,0	89,0	36,0	89,0	36,0	89,0	kg
	4,0	10,0	4,0	10,0	4,0	10,0	4,0	10,0	4,0	10,0	tiles

Panel: maximum dimensions 2100x1100 mm (24 kg)

Building height	0 - 5 meter		5 - 7 meter		7 - 9 meter		9 - 12 meter		12 - 15 meter		
	G1	G2	G1	G2	G1	G2	G1	G2	G1	G2	
27 m/s	36,0	82,0	36,0	82,0	36,0	82,0	36,0	82,0	36,0	82,0	kg
	4,0	9,5	4,0	9,5	4,0	9,5	4,0	9,5	4,0	9,5	tiles
30 m/s	36,0	106,0	36,0	106,0	36,0	106,0	36,0	106,0	36,0	106,0	kg
	4,0	12,0	4,0	12,0	4,0	12,0	4,0	12,0	4,0	12,0	tiles

X = the required ballast is higher than will fit under the system. The system must be mechanically attached to the roof. Please contact Van der Valk Solar Systems.

* If you use tiles of different sizes and thus another weight, you need to adjust the number of tiles to get the right weight.

Components

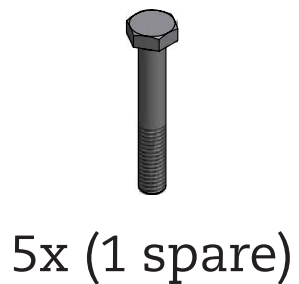
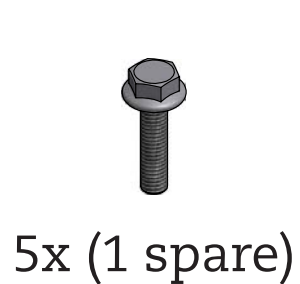
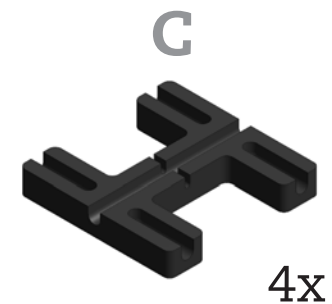
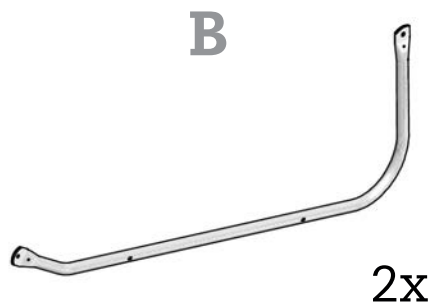
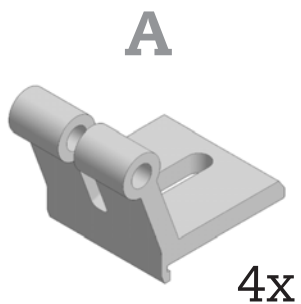

Step 1: Mounting the clevis

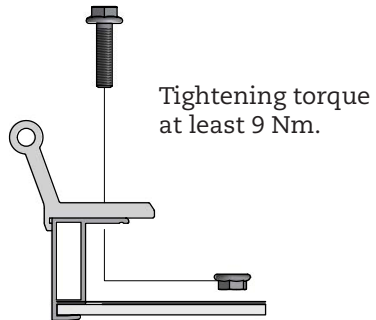
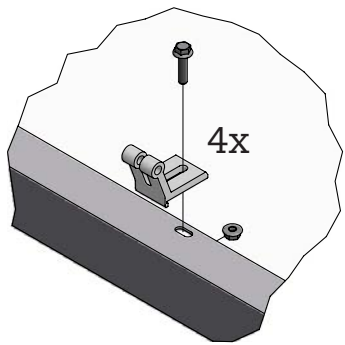
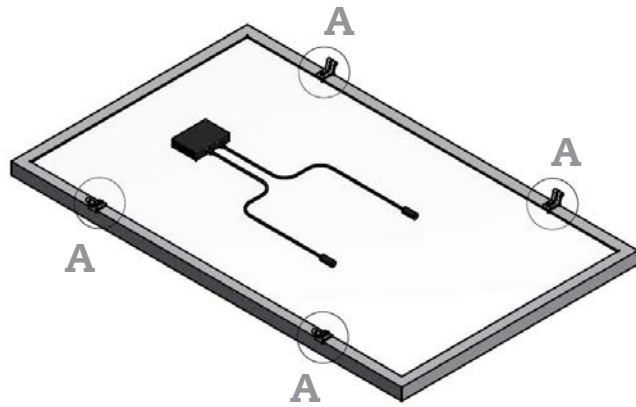

Step 2: Mounting the curved supports

The curved aluminum supports are suitable for panels with a width of 100 - 110 cm.

See other panel dimensions
on next page.

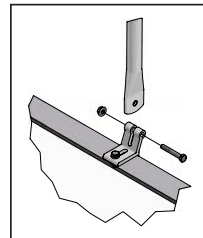
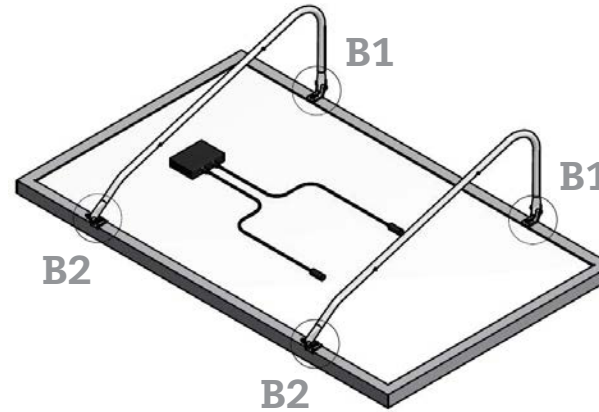

Tighten the hinge bolts B1 by hand. These must be removed temporarily at step 4.

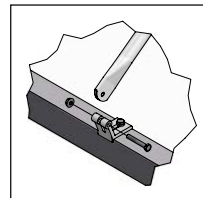

Tighten the hinge bolts B2 firmly, with a tightening moment of at least 9 Nm, until there is no play.

Option 1: Mounting panel

Suitable panel dimensions: 979 - 1005 mm
 (measured outside panel - outside panel)

Center to center mounting holes (panel frame): 959 - 985 mm

Under lip
 turned inwards

A (1 : 4)



Top lip facing
 inwards

B (1 : 4)

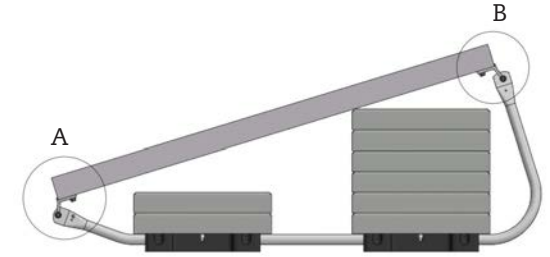
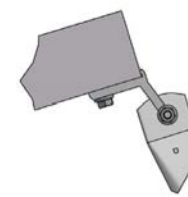

Option 2: Mounting panel

Suitable panel dimensions: 999 - 1025 mm
 (measured outer panel - inner frame)

Center to center mounting holes (panel frame): 999 - 1025 mm

Under lip
 turned inwards

A (1 : 4)



Top lip facing
 out

B (1 : 4)

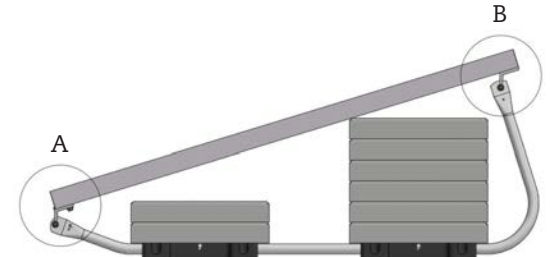
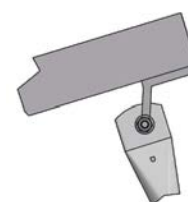

Option 3: Mounting panel

Suitable panel dimensions: 1019 - 1045 mm
 (measured within frame - within frame)

Center to center mounting holes (panel frame): 1039 - 1065 mm

Under lip facing
 outwards

A (1 : 4)

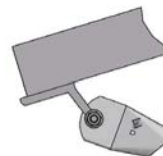

Top lip facing
 out

B (1 : 4)

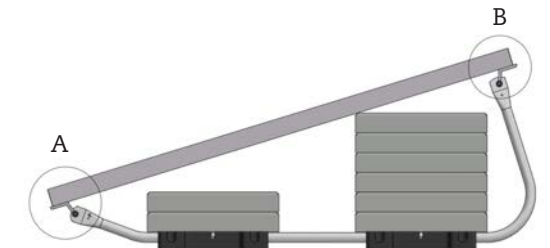
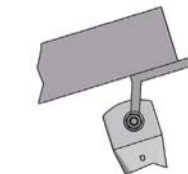

Step 3: Placing the rubber tiles

Turn over the panel and place it on the rubber tile carriers.

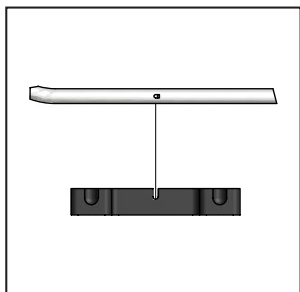
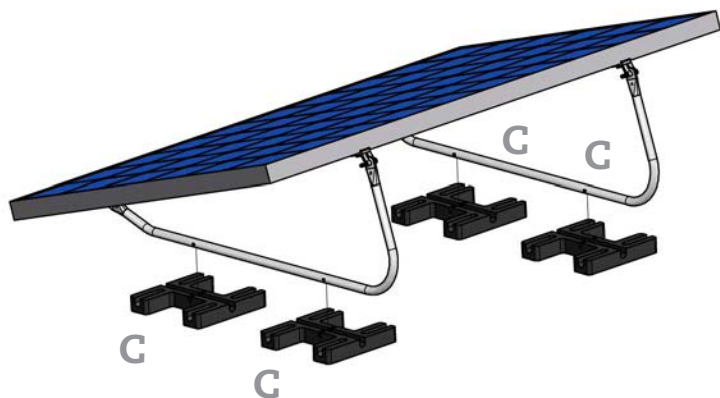

The projections on the curved aluminium supports must be placed in the grooves on the rubber tiles.

Step 4: Position the ballast

Remove the top hinge bolts B1 and place the panel in a vertical position. Make sure that you have some form of support in place or someone to hold the panel temporarily.

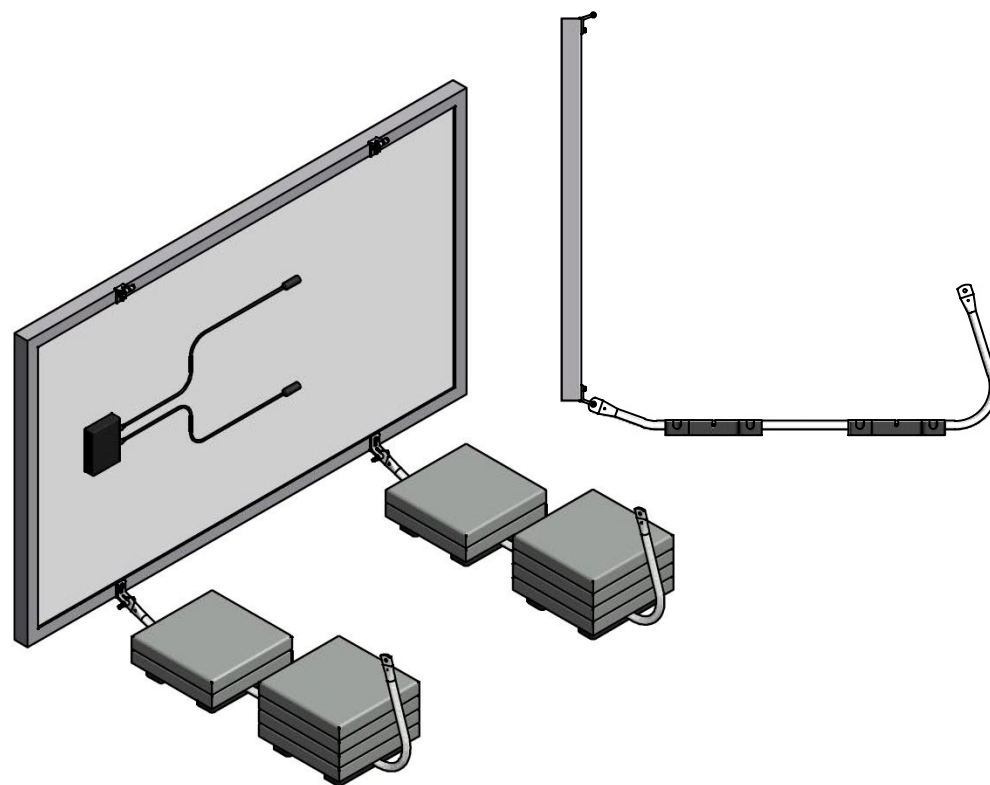

Position the ballast required.

Step 5: Tighten hinge bolts B1

Attach the panel to the curved supports again and tighten hinge bolts B1.

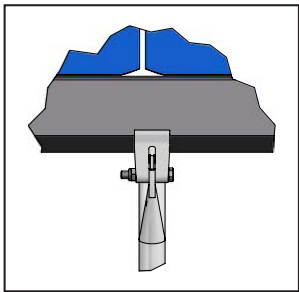
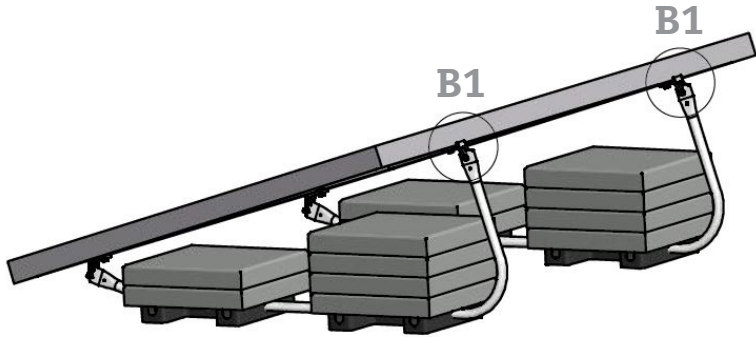

Tighten hinge bolts B1 tightly, with a tightening moment of at least 9 Nm, until there is no play.

Step 6: Finish fitting the cables

The loose cables can be secured to the edge of the panel. Using the cable clamps supplied.

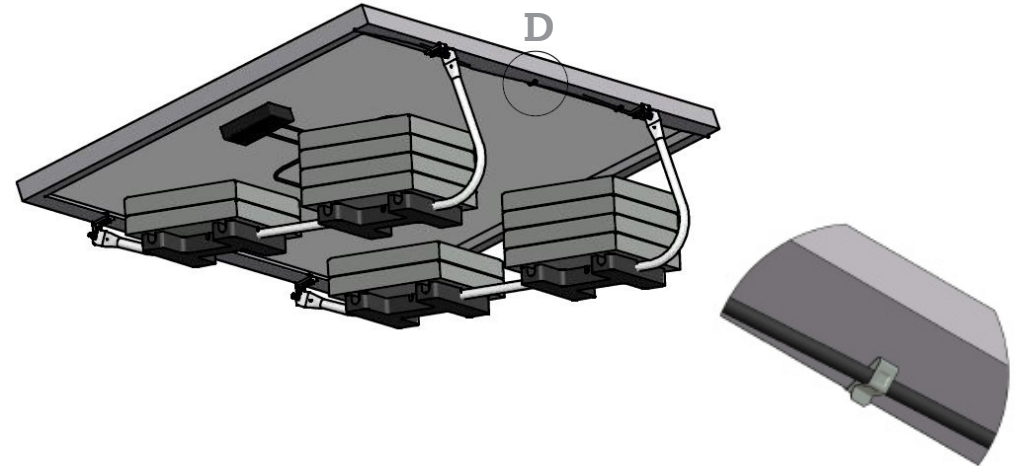

Step 7: Position the rows one behind each other

If a number of rows of panels are to be positioned one behind the other, we advise that an optimal pitch measure of 2.20 metres is observed; this will avoid any unwanted shadow. Optimal performance will be achieved if this pitch measure is used. Based on sun angle of 15 degrees.

